



PROVEN PERFORMER

Vended Laundry

STENXA (stack washer/dryer - electric),
STGNXA (stack washer/dryer - gas)

Stack washer/dryer features

- Improved suspension with new out-of-balance logic manages and redistributes unbalanced loads for uninterrupted wash cycles
- Water use as low as 44.3 litres per cycle to reduce operating costs
- Extended Tumble helps eliminate wrinkling by tumbling for two minutes at 20 minute intervals if the dryer door isn't opened
- Just like their stand-alone counterparts, Speed Queen stacks are 100 percent front serviceable to limit downtime for easy service access

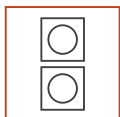

STACKABLE UNIT



STANDARD STAINLESS STEEL DRUM

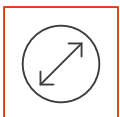

LARGE DOOR OPENING



LOW WATER CONSUMPTION



LOW ENERGY CONSUMPTION



COMPACT DESIGN

Controls

Quantum™ Gold

In addition to its network capabilities with our larger equipment and off-site management features, Quantum™ Gold offers additional owner and customer benefits such as PC programming and machine audit capabilities, as well as time-of-day pricing, a "lucky cycle" for loyal customers and the ability to interface with the store owner's card manufacturer of choice. Cycle modifier keys create additional profit opportunities for store owners.



STENXA, STGNXA

	STENXA (Electric)		STGNXA (Gas)	
Type	Stack Washer	Stack Dryer	Stack Washer	Stack Dryer
Control	Quantum	Quantum	Quantum	Quantum
Control location	Front	Front	Front	Front
Drum				
Capacity kg	9.5	8.2	9.5	8.2
Cylinder volume litres	96.8	198	96.8	198
Drum speed				
Spin speed G-Force	440	n/a	440	n/a
Spin speed rpm	1200	n/a	1200	n/a
Motor				
Motor size kW	Variable speed induction 0.67	0.25	Variable speed induction 0.67	0.25
Cabinet				
Cylinder finish	Stainless steel	Stainless steel	Stainless steel	Stainless steel
Colours	White	White	White	White
Door type (solid/window)	Window	Solid or Window	Window	Solid or Window
Heating				
Heat sources	n/a	Electric	n/a	Gas
Heating element (Electric W)		4000		n/a
Connection				
Gas inlet connection mm	n/a	n/a	n/a	9.5
Gas consumption BTU/Hr	n/a	25,000	n/a	25,000
Exhaust outlet dia. mm	n/a	102	n/a	102
Exhaust airflow litres/sec	n/a	60 Hz: 105, 50 Hz: 85	n/a	60 Hz: 105, 50 Hz: 85
Water temperatures	3	n/a	3	n/a
Operation				
Cycles*	Normal, Perm Press, Delicate	High, Medium, Low, Delicates, No Heat	Normal, Perm Press, Delicate	High, Medium, Low, Delicates, No Heat
Water consumption per cycle litres*	44.3	n/a	44.3	n/a
Water pressure bar	1.4/8.3	n/a	1.4/8.3	n/a
Cycle indicator lights	Yes	Yes	Yes	Yes
Power				
Electrical requirements (voltage/Hz/Ph)	240/50/1		240/50/1	
Transport data				
Net weight kg	177 (combined)		177 (combined)	
Shipping weight kg	193 (combined)		193 (combined)	
Dimensions H×W×D mm	1986×683×704		1986×683×704	
Packing dimensions H×W×D mm	2032×737×832		2032×737×832	
Agency approvals				
Available agency approvals	See price sheet for applicable agency approvals by market		See price sheet for applicable agency approvals by market	

*Information provided applies to premier control offered by product class.



Dimensions

Stack Washer/Dryer – electric

	A	B	C	D	E	F	G	H	I	J	K	L	M	N	O	P	Q
STENXA	1678*	1447*	597	213	610	203	391	938*	368*	813*	683	1184*	1986*	52	704	38	333*

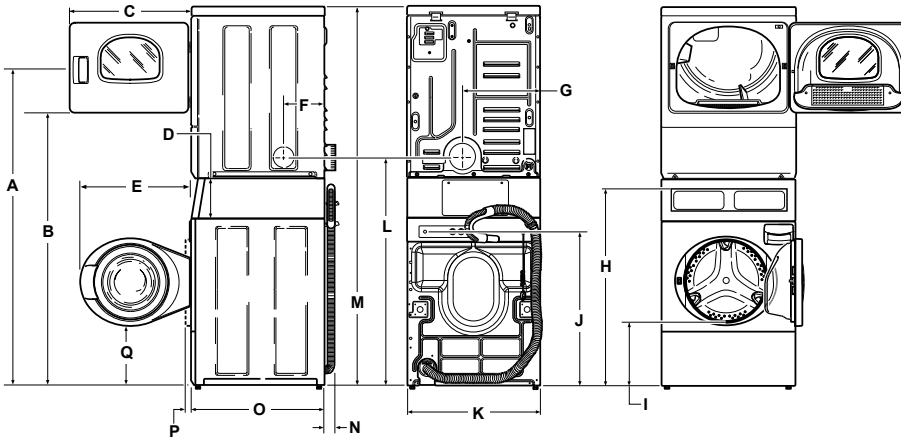

Stack Washer/Dryer – gas

	A	B	C	D	E	F	G	H	I	J	K	L	M	N	O	P	Q	R
STGNXA	1678*	1447*	597	213	610	203	391	59	938*	368*	1140*	813*	683	1184*	1986*	52	704	38

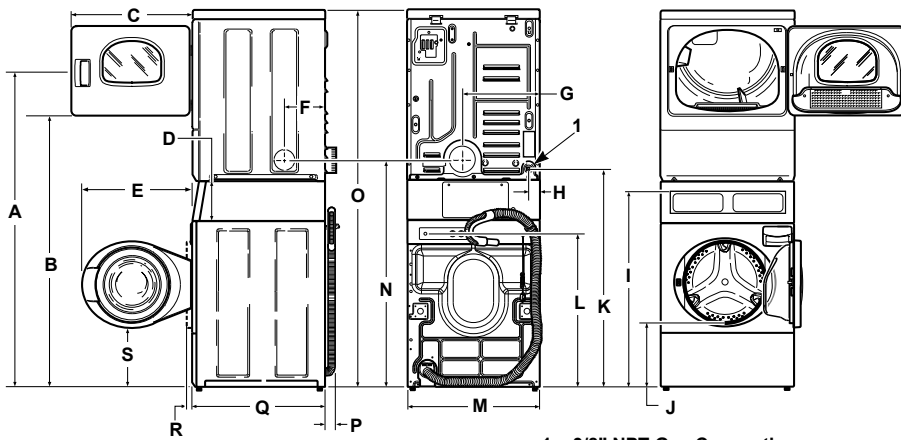

1 = 3/8" NPT Gas Connection

All measurements are in mm. *With levelling legs turned into base.

NOTE: Exhaust openings are 102 mm metal ducting.

