



PROVEN PERFORMER

Vended Laundry

SFNNXA (front loading washers),

SDENXA (electric dryer), SDGNXA (gas dryer)

Front loading washer features

- Improved suspension with new out-of-balance logic
- High spin speed up to 1,200 rpm removes more water from clothes, speeding up drying cycles and lowering dryer energy usage
- Heavy-duty construction
- A pump drain allows our front load washers to be installed adjacent to or replace top load washers with no special plumbing
- Redesigned supply dispenser features four compartments and automatically dispenses as needed for a complete wash

Dryer features

- Durable galvanized steel cylinder with an extra-large 198 litres of volume
- Efficient dryer heating with 6,300 kCal (gas models) and up to 4,000 Watts (electric models)
- Extended tumble helps eliminate wrinkling
- Quiet, efficient blower system uses a superior airflow of 5100 litres per minute
- 1913.8 sq. cm door opening is the largest in the industry, providing easy loading and unloading for customers



STANDARD STAINLESS STEEL DRUM



LARGE DOOR OPENING



LOW WATER CONSUMPTION



LOW ENERGY CONSUMPTION



COMPACT DESIGN

Controls

Quantum™ Gold

In addition to its network capabilities and off-site management features, Quantum™ Gold offers additional owner and customer benefits such as PC programming and machine audit capabilities, as well as time-of-day pricing, a "lucky cycle" for loyal customers and the ability to interface with the store owner's payment systems. Cycle modifier keys create additional profit opportunities for store owners.



SFNNXA



SFNNXA (Stainless steel)



SDENXA, SDGNXA

	SFNNXA SFNNXA (Stainless steel)	SDEXA SDGNXA
Type	Front Loading Washer	Single Dryer
Control	Quantum	Quantum
Control location	Front	Front
Drum		
Capacity kg	9.5	8.2
Cylinder volume litres	96.8	198
Width mm	683	683
Depth mm	704	711
Height mm	1126	1126
Drum speed		
Spin speed G-Force	440	n/a
Spin speed rpm	1200	n/a
Motor		
Motor size kW	Variable speed induction 0.67	0.25
Cabinet		
Cylinder finish	Stainless steel	Galvanized
Colours	White, Stainless steel	White
Door type (solid/window)	Window	Solid
Heating		
Heat sources	n/a	Gas or Electric
Heating element (Electric W)	n/a	4000
Connection		
Gas inlet connection mm	n/a	9.5
Gas consumption BTU/Hr	n/a	25,000
Exhaust outlet dia. mm	n/a	102
Exhaust airflow litres/sec	n/a	60 Hz: 105 (220), 50 Hz: 85 (180)
Water temperatures	3	n/a
Operation		
Cycles*	Normal, Perm Press, Delicate	High, Medium, Low, Delicates, No Heat
Water consumption per cycle litres*	44.3	n/a
Water pressure bar	1.4/8.3	n/a
Cycle indicator lights	Yes	Yes
Power		
Electrical requirements (voltage/Hz/Ph)	240/50/1	240/50/1
Transport data		
Net weight kg	122	Electric/Gas 68/70
Shipping weight kg	132	Electric/Gas 73/75
Dimensions H×W×D mm	1126×683×704	1126×683×711
Packing dimensions H×W×D mm	1156×737×832	1156×737×832
Agency approvals		
Available agency approvals	See price sheet for applicable agency approvals by market	

*Information provided applies to premier control offered by product class.



Dimensions

Front Loading Washer

	A	B	C	D	E	F	G	H	I	J
SFNNXA	610	1126	813	938	371	683	52	704	40	333

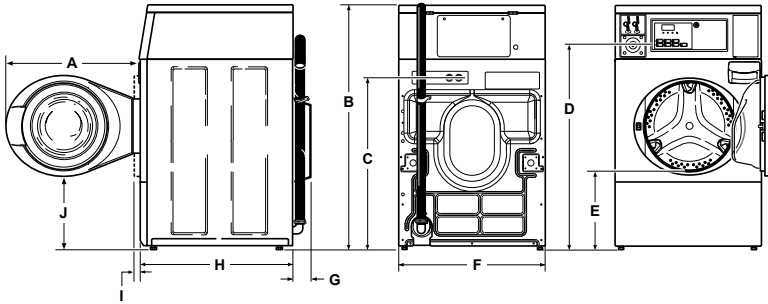

Electric Dryer

	A	B	C	D	E	F	G	H	I	J	K
SDENXA	1126*	938*	392*	102*	391	683	114*	10	203	711	597

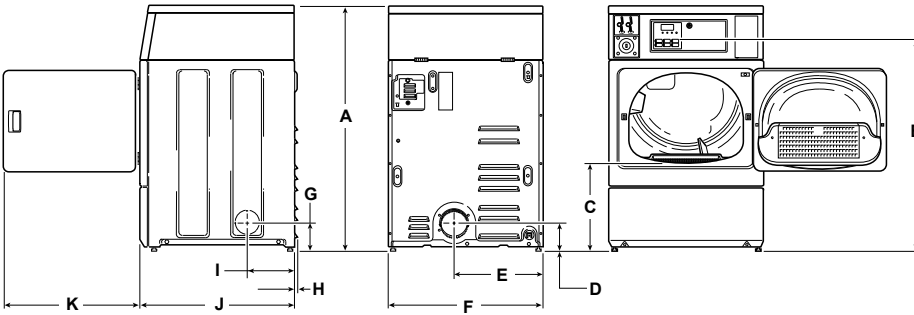

Gas Dryer

	A	B	C	D	E	F	G	H	I	J	K	L	M
SDGNXA	1126*	938*	392*	102*	70*	60	391	683	114*	10	203	711	597

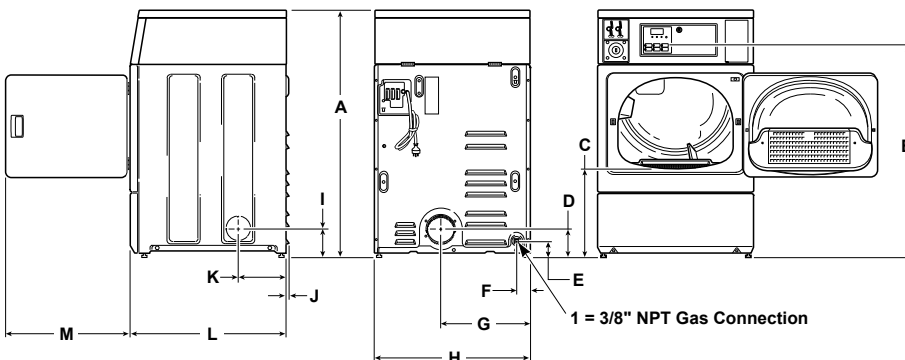

Gas models cannot be vented out left side of cabinet because of burner housing.

IMPORTANT: The dryer should have sufficient clearance around it for needed ventilation and for the ease of installation and servicing. For maximum drying performance, we recommend that more clearance be allowed around the dryer than the clearances that are listed here.

All measurements are in mm. *With levelling legs turned into base.

NOTE: Exhaust openings are 102 mm metal ducting.

